

Part number

CMI 16 CS



Brief description:

bulkhead mounting housings with 4 pegs, size "104.27" insulated 830V version, metal cover, insulated 830V version, IP65

Product description

Version	insulated 830V version
Series	Bulkhead housings, with 4 pegs
Product type	with 4 pegs and gasket
Variant	metal cover
Family	830V enclosures for CME inserts
Size	size "104.27" insulated 830V version

Technical data

Operating temperature range (min, max)	-40°C ... +125°C
Material	metal
IP degree of protection	IP65

Further technical details

Weight	175,00 g
---------------	----------

Approvals / Standards

Quality mark	 (type:4/4X/12),  , EAC
Conformity	CQC, CE

General ordering information

EAN13 code	8015747030762
Tariff number	85369095

Packaging Information

Packaging length	330,00 mm
Packaging height	210,00 mm
Packaging width	180,00 mm
Packaging weight	3,50 kg
Packaging volume	12,47 dm ³
Packaging description	Carton box
Packaging quantity	20 Pcs
Packaging EAN code	8015747234191
Sub-packaging weight	0,88 kg
Sub-packaging description	Plastic packaging
Sub-packaging quantity	5 Pcs
Sub-packaging EAN barcode	8015747030779

Part number

CMI 16 CS



Catalogue drawings

CMI

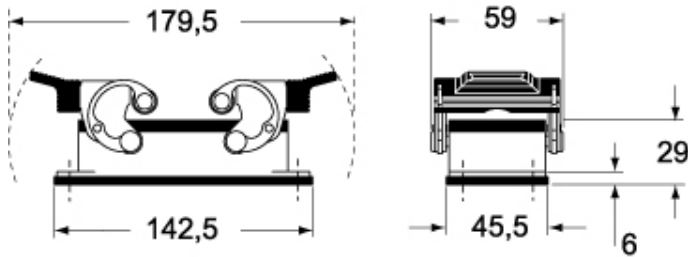

CMI CS/CP

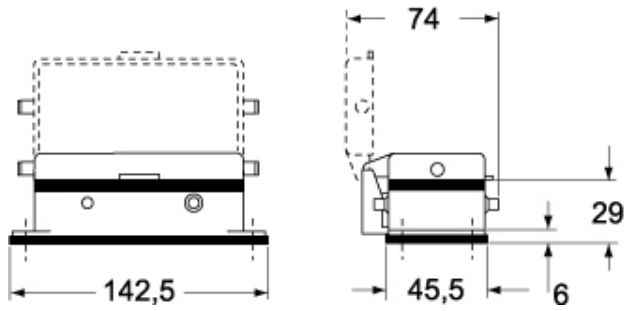

Catalogue drawings

